

TYPE: DCE

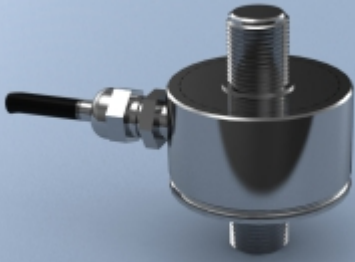

DCE Tension & Compression Stainless Steel Load Cell

Description

The LCM Systems DCE load cell has been developed for applications that require the measurement of tensile and compressive forces, where space is limited. As with most LCM products, there are special variants that are available for this product. Popular modifications include different thread sizes, integral connectors and high temperature versions.

Typical applications include component testing, weighing systems and general force measurement.

The DCE can be supplied on its own or integrated with any of the wide range of instrumentation products available from LCM Systems.

Features

- Ranges: 100N to 50kN
- Stainless steel construction
- Environmentally sealed to IP65
- Special sizes and ranges available
- Different mounting options available

Specification

Rated load (Newtons) (Kilonewtons)	100, 250, 500 750 1, 2.5, 5, 7.5, 10, 25, 50
Proof load	150% of rated load
Ultimate breaking load	>300% of rated load
Maximum side load	10% of rated load
Output	1.5mV/V at rated load (nominal)
Non-Linearity	<±0.25% of rated load
Non-Repeatability	<±0.1% of rated load
Excitation voltage	10vdc recommended, 15vdc maximum
Bridge resistance	350Ω (25kN and 50kN: 700Ω)
Insulation resistance	>500MΩ @500vdc
Operating temperature range	-20 to +70°C
Compensated temperature range	-10 to +50°C
Zero temperature coefficient	<±0.01% of rated load/°C
Span temperature coefficient	<±0.01% of rated load/°C
Environmental protection level	IP65
Connection type	2 metres 4-core screened PVC cable
Wiring connections	+ve supply: Red -ve supply: Blue +ve signal: Green -ve signal: Yellow

Typical Applications

- General force measurement
- Wire tension measurement
- Tensile testing

Available Options

- Special ranges and sizes available
- Rationalised output available
- Different thread sizes available
- Integral connector option
- High temperature variants
- Different mounting options
- TEDS option (when used with TR150 handheld display)

LCM Systems Ltd

Unit 15, Newport Business Park
Barry Way, Newport
Isle of Wight PO30 5GY UK
Tel: +44 (0)1983 249264
Fax: +44 (0)1983 249266
sales@lcm systems.com
www.lcm systems.com

DCE Tension & Compression Stainless Steel Load Cell

Dimensions

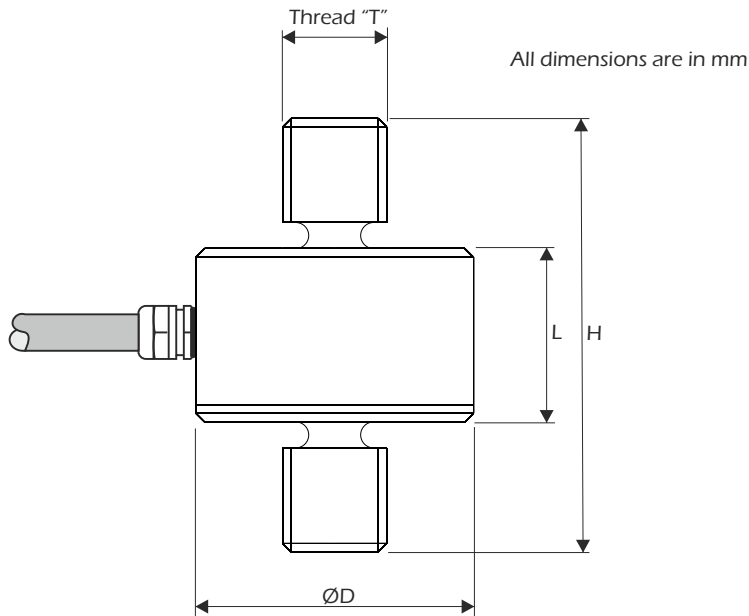

Rating	Part Number	Thread "T"	ØD	L	H	Weight (g)	Resolution
100N	DCE-100N	M4 x 0.7	20	13	29	30	0.1N
250N	DCE-200N	M4 x 0.7	20	13	29	30	0.2N
500N	DCE-500N	M4 x 0.7	20	13	29	30	0.5N
750N	DCE-750N	M4 x 0.7	20	13	29	30	1N
1kN	DCE-1KN	M5 x 0.8	20	13	33	30	0.001kN
2.5kN	DCE-2.5KN	M5 x 0.8	20	13	33	30	0.002kN
5 kN	DCE-5KN	M10 x 1.0	32	20	45	45	0.005kN
7.5kN	DCE-7.5KN	M10 1.0	32	20	45	45	0.01kN
10kN	DCE-10KN	M12 x 1.75	38	22	52	45	0.01kN
25kN	DCE-25KN	M20 x 1.5	38	24	84	45	0.02kN
50kN	DCE-50KN	M24 x 2.0	38	30	102	45	0.05kN

Note: default calibration of these load cells will be in tension. If you require calibration in compression or both tension & compression, please state at time of order (additional charges may apply).



www.lcmsystems.com



SCIGATE AUTOMATION (S) PTE LTD

No. 1 Bukit Batok Street 22 #01-01 Singapore 659592

Tel: (65) 6561 0488

Fax: (65) 6562 0588

Email: sales@scigate.com.sg

Web: www.scigate.com.sg

Business Hours: Monday - Friday 8.30am - 6.15pm

Due to continual product development, LCM Systems Ltd reserves the right to alter product specifications without prior notice.

Issue No. 4

Issue date: 18/10/2016

APPROVED

(unapproved if printed)